







# 4WD Mecanum Wheel Robot Chassis

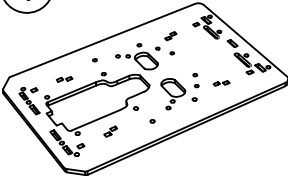
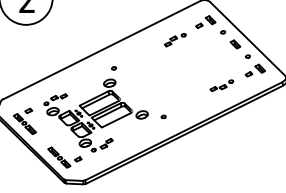
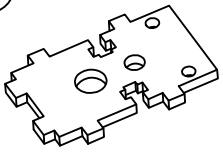
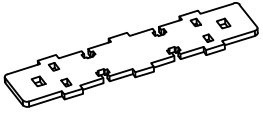
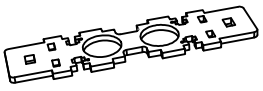
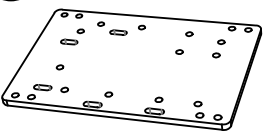
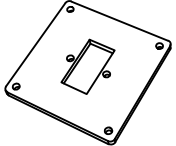

BALIA DAGU

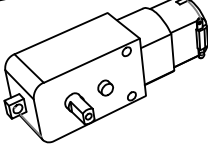
-- HC309 --

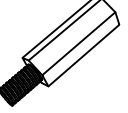
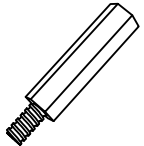
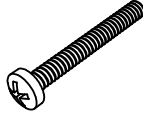
Part list:

<p>①</p>  <p>Chassis-up 1 PCS</p>	<p>②</p>  <p>chassis-bottom 1 PCS</p>	<p>③</p>  <p>Motor fixing plate 4 PCS</p>	<p>④</p>  <p>motor positioning plate 1 PCS</p>	<p>⑤</p>  <p>Fixed block for ultrasonic module 1 PCS</p>
<p>⑥</p>  <p>Chassis-TP 1 PCS</p>	<p>⑦</p>  <p>Mechanical arm fixing block 1 PCS</p>	<p>⑧</p>  <p>MK-Wheel 4 PCS</p>	<p>⑨</p>  <p>TT-motor 4 PCS</p>	<p>⑩</p>  <p>L22 CU-shore 2 PCS</p>
<p>⑪</p>  <p>L15 Nylon-shore 4 PCS</p>	<p>⑫</p>  <p>L20 Nylon-shore 4 PCS</p>	<p>⑬</p>  <p>M3*25 screw 8 PCS</p>	<p>⑭</p>  <p>M3*8 screw 24 PCS</p>	<p>⑮</p>  <p>M3 Nut 24 PCS</p>

Assembly instruction: ( ☆ Remove and remove the protective film before installation )

Step 1:

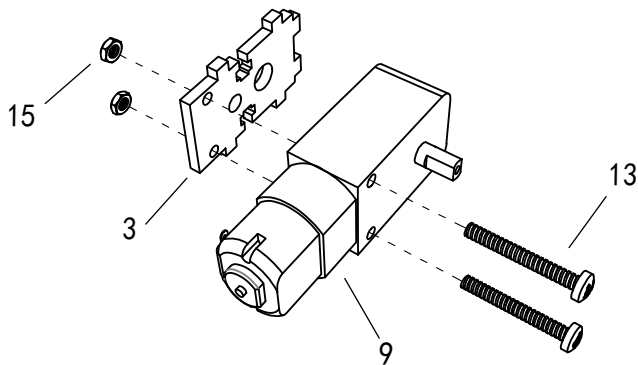

☆ Measure the length of screw with this ruler

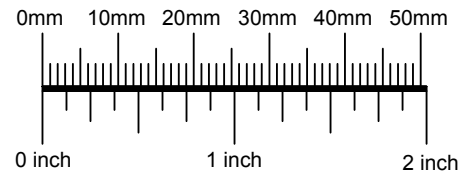

Step 2:

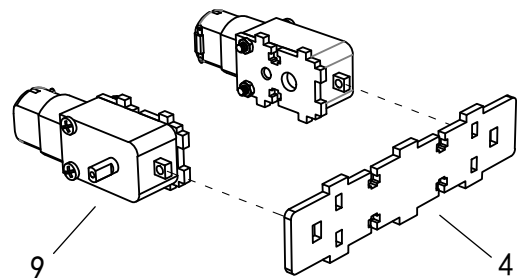

Step 3:

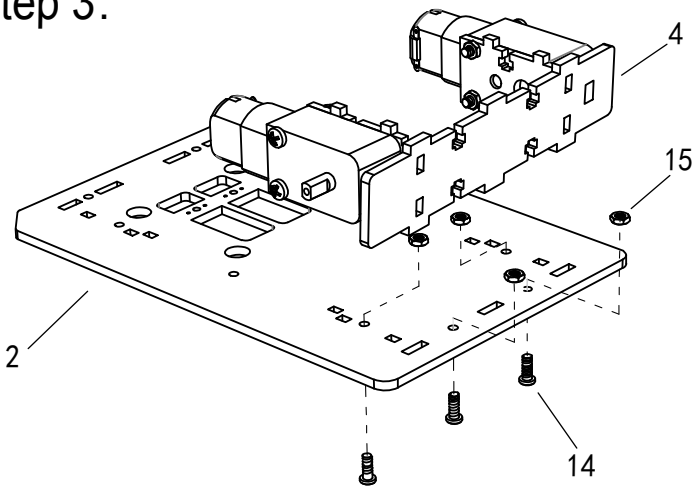

Step 4:

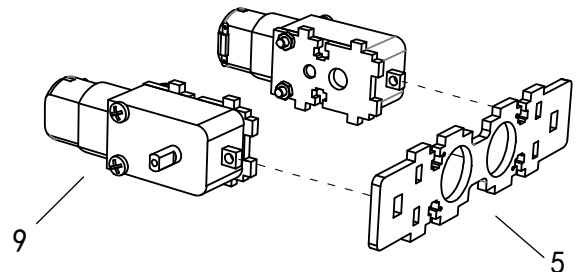

Step 5:

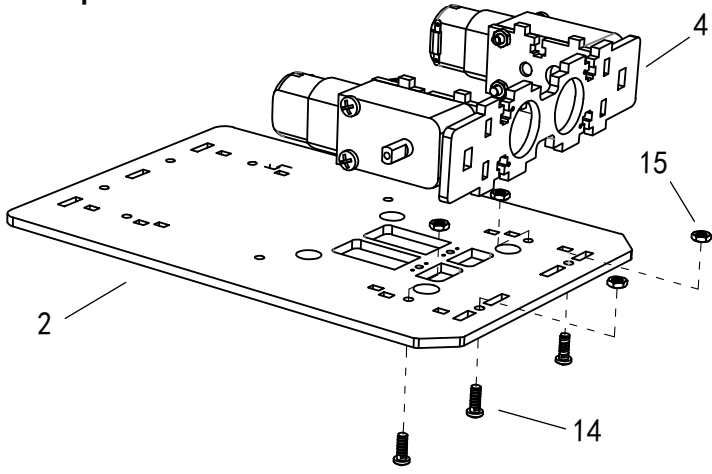

Step 6:

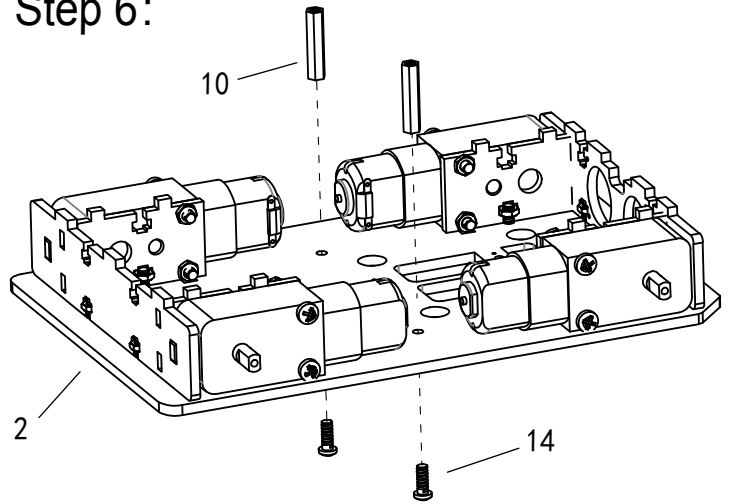

Step 7:

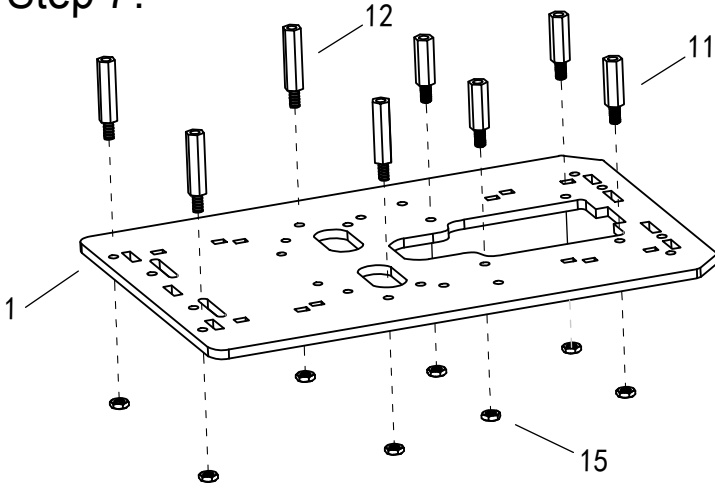

Step 8:

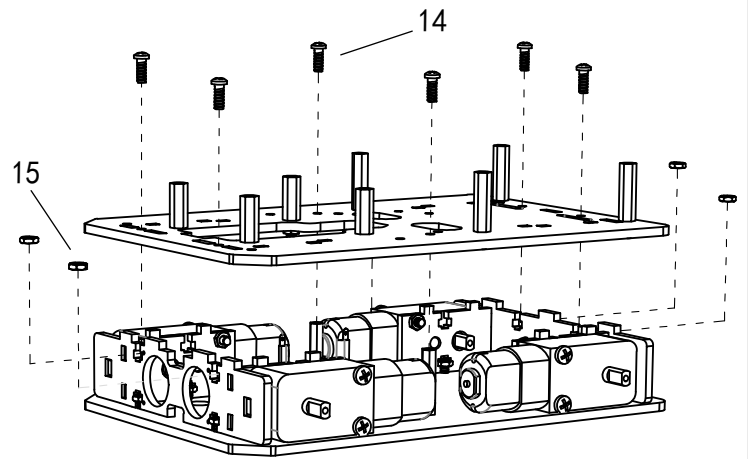

Step 9:

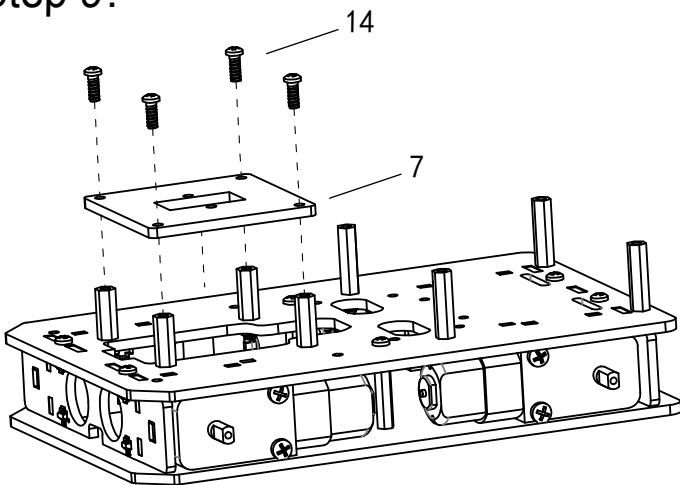

Step 10:

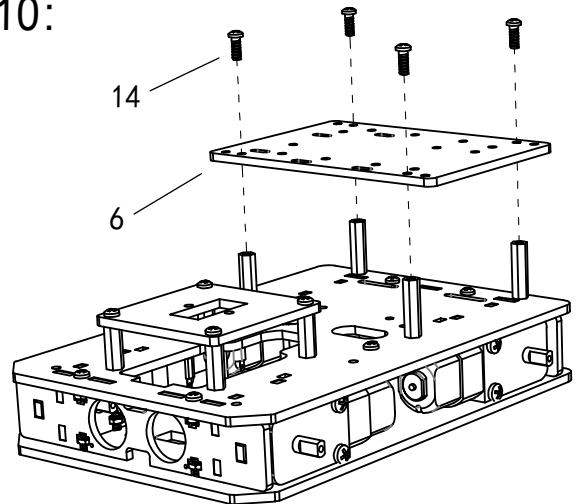

Step 9:

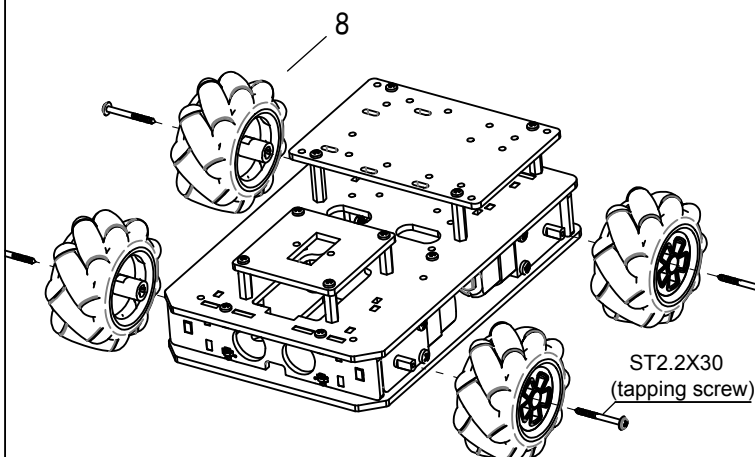

Finished:

