

□ 28.2mm (□ 1.11in.)

Step Angle 1.8° 11HS High-Torque Type

Common Rating

| Item | Specification |
|-----------------------|---------------------------------------|
| Step Angle Accuracy | ±5% (full step, no load) |
| Resistance Accuracy | ±10% |
| Inductance Accuracy | ±20% |
| Temperature Rise | 80°C Max. (rated current, 2 phase on) |
| Ambient Temperature | -10°C ~ +50°C |
| Insulation Resistance | 100MΩ Min. 500VDC |
| Dielectric Strength | 500VAC for one minute |
| Shaft Radial Play | 0.02Max. (450 g-load) |
| Shaft Axial Play | 0.08Max. (450 g-load) |



Dimension Unit = mm(in.)

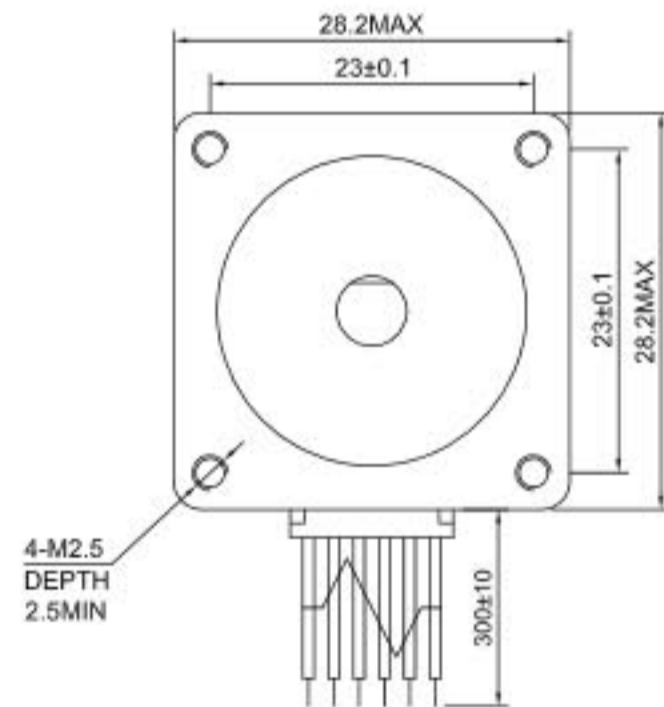
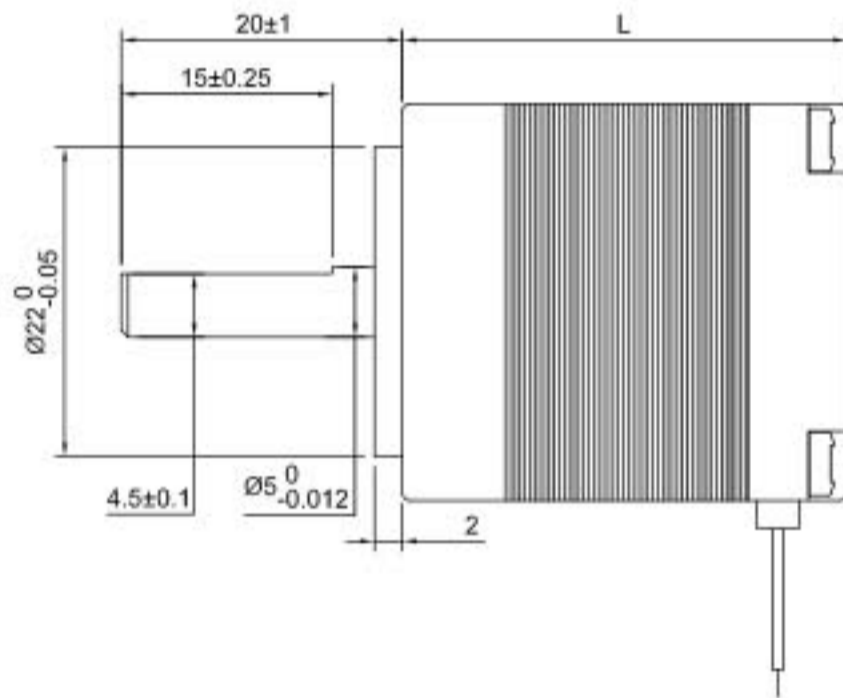

Wiring Diagram

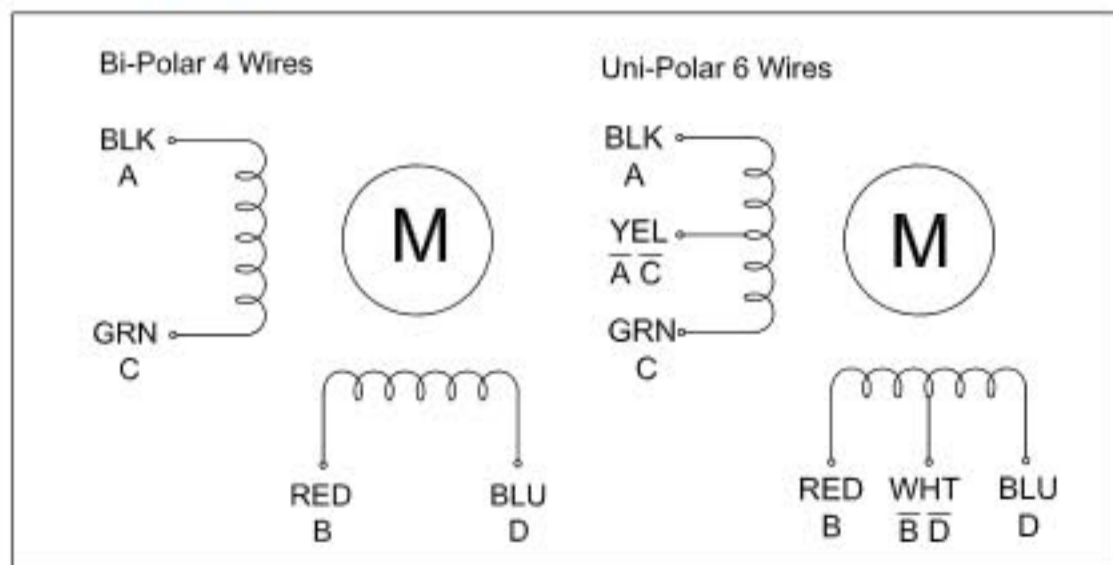

Excitation Sequence

| Excitation: 2-2 | | | | | Excitation: 2-1-2 | | | | |
|-----------------|---|---|---|---|-------------------|---|---|---|---|
| STEP | A | B | C | D | STEP | A | B | C | D |
| 1 | + | + | | | 1 | + | | | |
| 2 | | + | + | | 2 | + | + | | |
| 3 | | | + | + | 3 | | + | | |
| 4 | + | | | + | 4 | | + | + | |
| | | | | | 5 | | | + | |
| | | | | | 6 | | | + | + |
| | | | | | 7 | | | | + |
| | | | | | 8 | + | | | + |

Specifications

| Model | Torque | | Voltage | Current | Resistance | Inductance | Inertia | Bi/Unipolar | Weight | Length "L" | |
|--------------|--------|-------|---------|---------|------------|------------|-------------------|-------------|--------|------------|------|
| | Ncm | oz.in | V/Phase | A/Phase | Ohm/Phase | mH/Phase | g.cm ² | # of Leads | Kg | mm | in |
| 11HS18-0956S | 7.5 | 10.6 | 3.2 | 0.95 | 3.4 | 1.2 | 12 | Uni (6) | 0.14 | 44.5 | 1.75 |