

Display Elektronik GmbH

DATA SHEET

LCD MODULE

DEM 16209 FGH-PW

Product Specification

Ver.: 1

11/Dec./2009

DOCUMENT REVISION HISTORY

Version	DATE	DESCRIPTION	CHANGED BY
0	Oct-27-2009	First Issue	MH
1	Dec-11-2009	Update Backlight Characteristics	MH

CONTENTS

1. Functions & Features	2
2. Mechanical Specifications	2
3. Block Diagram	2
4. Dimensional Outline	3
5. Pin Description	4
6. Maximum Absolute Limit	4
7. Electrical Characteristics	5
8. Timing Characteristics	6
9. Control and Display Command	7
10. Font Characteristic	8
11. Backlight Characteristics	9
12. Electro-Optical Characteristics	10
13. Precaution for using LCD/LCM	11

1. FUNCTIONS & FEATURES

Display Format	: 16x2 Characters, COG
LCD Mode	: FSTN / Positive / Transflective
Viewing Direction	: 6 o'clock
Driving Scheme	: 1/16 Duty cycle, 1/5 Bias
Power Supply Voltage (V _{DD})	: 5.0 Volt (typ.)
LCD Driving Voltage (V _{LCD})	: 4.5 Volt (Typ. Reference Voltage)
Operation Temperature	: -20°C to +70°C
Storage Temperature	: -30°C to +80°C
Backlight	: LED, White, Lightguide

2. MECHANICAL SPECIFICATIONS

Module Size	: 76.00 x 28.70 x 6.00 mm
Viewing Area	: 61.00 x 15.70 mm
Character Pitch	: 3.55 x 5.75 mm
Character Size	: 2.95 x 5.15 mm
Dot Pitch	: 0.60 x 0.65 mm
Dot Size	: 0.55 x 0.60 mm

3. BLOCK DIAGRAM

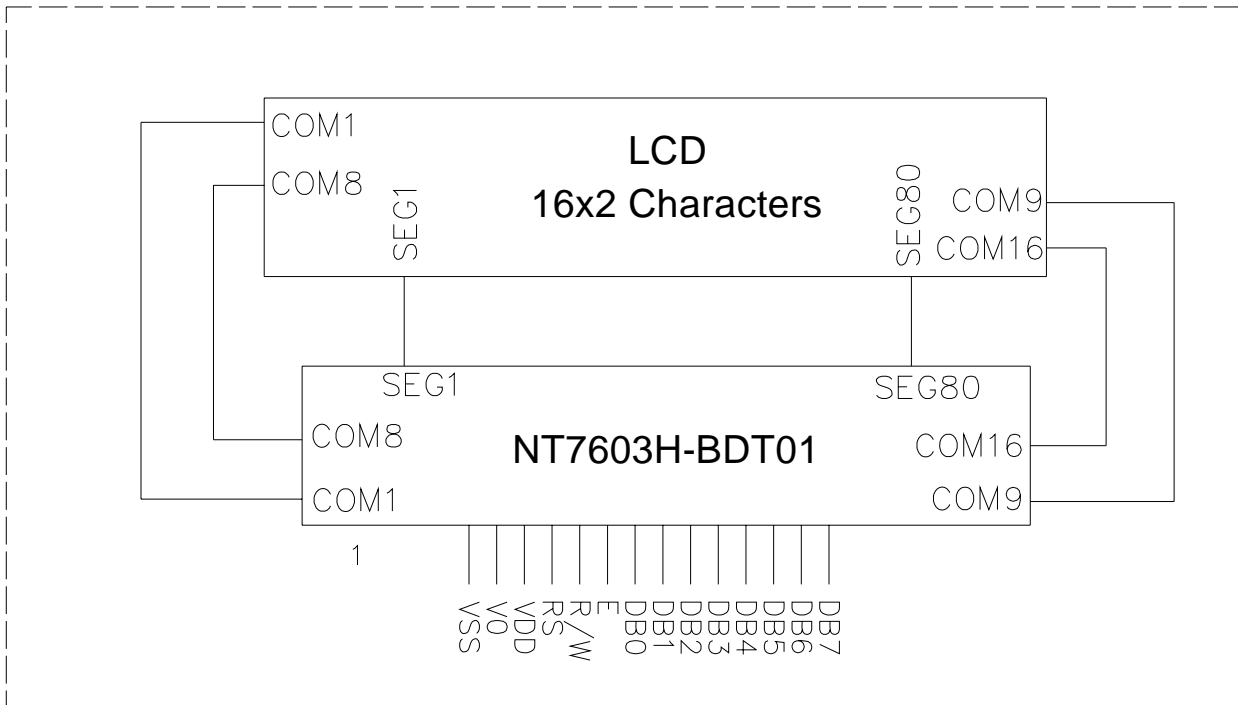

4. DIMENSIONAL OUTLINE

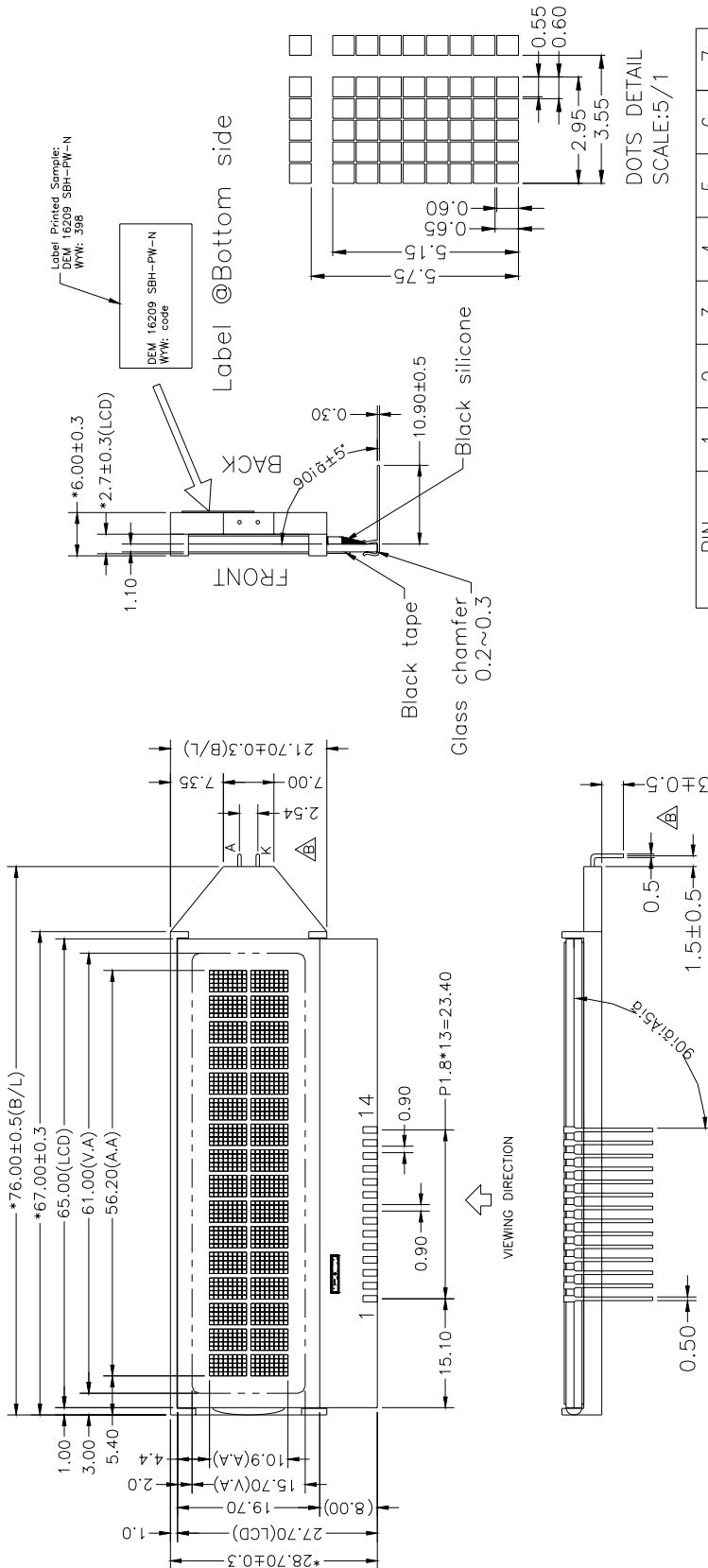

DOTS DETAIL
SCALE:5/1

PIN	1	2	3	4	5	6	7
CONNECTION	VSS	V0	VDD	RS	R/W	E	DB0
PIN	8	9	10	11	12	13	14
CONNECTION	DB1	DB2	DB3	DB4	DB5	DB6	DB7

- Specification:
- 1). Driving: Duty:1/16, Bias:1/5, VLCD:4.5V(Ref), VDD:5.0V
 - 2). Viewing angle: 6 O'clock
 - 3). Display mode: FSTN/Positive/Transflective
 - 4). Operating temp.: -20°C?+70°C
Storage temp.: -30°C?+80°C
 - 5). IC: NT7603 (or compatible)
 - 6). BackLight: EDGE White (1 DIP, If=15mA ,Vf=3.1±0.2V)
 - 7). Dimensions with mark "*" are important, with mark "()" are referenced
 - 8). All the raw materials are RoHS compliant

5. PIN DESCRIPTION

No.	Symbol	Function
1	VSS	Power supply(-)
2	V0	Power supply for LCD driver
3	VDD	Power supply(+5.0V)
4	RS	Register select signal 0: Instruction register (write), Busy flag, address counter (read) 1: Data register (write, read)
5	R/W	Read/Write control signal 0: Write 1: Read
6	E	Read/Write start signal
7~14	DB0~DB7	Date Bus Lines

6. MAXIMUM ABSOLUTE LIMIT

Item	Symbol	MIN	MAX	Unit
Supply Voltage for Logic	V _{DD}	-0.3	7.0	V
Supply Voltage for LCD	V ₀	GND	V _{DD} +0.3	V
Input Voltage	V _{in}	-0.3	V _{DD} +0.3	V
Supply Current for Backlight	I _F (Ta = 25°C)	---	15+15*20%	mA
Reverse Voltage for Backlight	V _R (Ta = 25°C)	---	5	V
Operating Temperature	T _{op}	-20	70	°C
Storage Temperature	T _{st}	-30	80	°C

7. ELECTRICAL CHARACTERISTICS

DC Electrical Characteristics (continued)

 $V_{DD}=5.0V, GND=0V, T_A=25^{\circ}C$

Symbol	Parameter	Min.	Typ.	Max.	Unit	Conditions	Applicable Pin
V _{DD}	Operating Voltage	3.0	3.3	3.6	V		
V _{IH1}	"H" Level Input Voltage (1)	0.8 V _{DD}	-	V _{DD}	V		DB0 - DB7, RS, R/W, E, OSC1
V _{IL1}	"L" Level Input Voltage (1)	-0.3	-	0.2 V _{DD}	V		
V _{OH1}	"H" Level Output Voltage (1)	V _{DD} - 0.4	-	-	V	I _{OH} = -0.8mA	DB0 - DB7 (CMOS)
V _{OL1}	"L" Level Output Voltage (1)	-	-	GND + 0.4	V	I _{OL} = 0.8mA	
V _{COM}	Driver Voltage Descending (COM)	-	-	0.3	V	I _D = 5μA	COM1 - 16
V _{SEG}	Driver Voltage Descending (SEG)	-	-	0.3	V	I _D = 5μA	SEG1 - 80
I _{IL}	Input Leakage Current	-1	-	1	μA	V _{IN} = 0 to V _{DD}	Not include OSC1
-I _P	Pull-up MOS Current	30	75	150	μA	V _{DD} = 3V	RS, R/W, DB0-DB7
I _{OP}	Power Supply Current	-	1	1.5	mA	Rf oscillation, from external clock V _{DD} = 3.0V, f _{osc} = f _{CP} = 540KHz, include LCD bias current.	V _{DD}
External Clock Operation							
f _{CP}	External Clock Operating Frequency	380	540	750	KHz		
t _{DUTY}	External Clock Duty Cycle	45	50	55	%		
t _{RCP}	External Clock Rising Time	0.1	-	0.5	μS		
t _{FCP}	External Clock Falling Time	0.1	-	0.5	μS		
Internal Clock Operation (Built-in RC Oscillator)							
f _{OSC}	Oscillator Frequency	380	540	750	KHz	Rf = 50KΩ (reference only) V _{DD} = 2.8V ~ 5.5V	
V _{LCD}	LCD Driving Voltage	2.5	-	V _{DD}	V	V _{DD} - V5	

8. TIMING CHARACTERISTICS

Read Operation

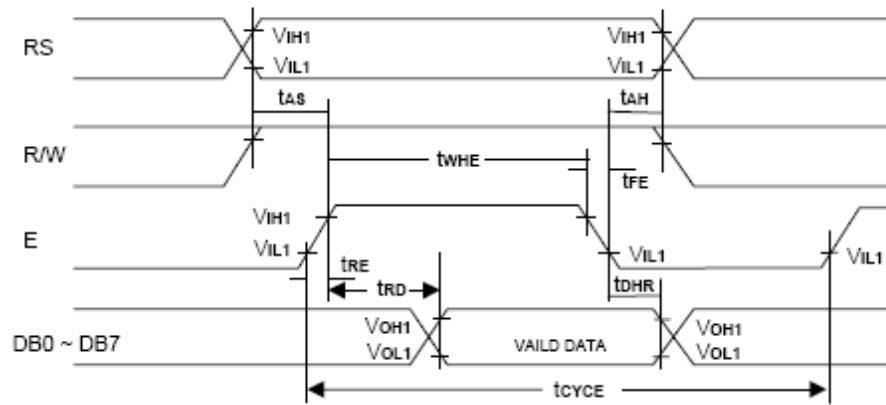

Figure 1. Bus Read Operation Sequence
(Reading out data from NT7603 to 8-bit MPU)

Write Operation

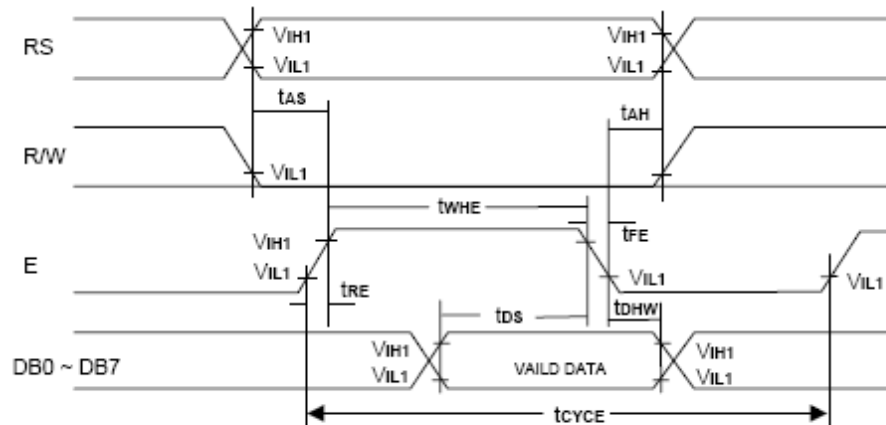

Figure 2. Bus Write Operation Sequence
(Writing data from 8-bit MPU to NT7603)

Interface Signals with Segment Driver LSI



Figure 3. tOFF stipulates the time of power OFF for instantaneous Power supply to or when power supply repeats ON and OFF

9. CONTROL AND DISPLAY INSTRUCTION

Instruction	Code										Function	Execution time (max) (fOSC = 540KHz)	
	RS	RW	DB7	DB6	DB5	DB4	DB3	DB2	DB1	DB0			
Display Clear	0	0	0	0	0	0	0	0	0	0	1	Clear entire display area, Restore display from shift, and load address counter with DD RAM address 00H.	1.64ms
Display/ Cursor Home	0	0	0	0	0	0	0	0	0	1	*	Restore display from shift and load address counter with DD RAM address 00H.	1.64ms
Entry Mode Set	0	0	0	0	0	0	0	0	1	I/D	S	Specify direction of cursor movement and display shift mode. This operation takes place after each data transfer (read/write).	40μs
Display ON/OFF	0	0	0	0	0	0	0	1	D	C	B	Specify activation of display (D) cursor (C) and blinking of character at cursor position (B).	40μs
Display/ Cursor Shift	0	0	0	0	0	0	1	S/C	R/L	*	*	Shift display or move cursor.	40μs
Function Set	0	0	0	0	1	DL	N	F	*	*		Set interface data length (DL), number of display line (N), and character font (F).	40μs
RAM Address Set	0	0	0	1	ACG							Load the address counter with a CG RAM address. Subsequent data access is for CG RAM data.	40μs
DD RAM Address Set	0	0	1	ADD							Load the address counter with a DD RAM address. Subsequent data access is for DD RAM data.	40μs	
Busy Flag/ Address Counter Read	0	1	BF	AC							Read Busy Flag (BF) and contents of Address Counter (AC).	1μs	
CG RAM/ DD RAM Data Write	1	0	Write data									Write data to CG RAM or DD RAM.	40μs
CG RAM/ DD RAM Data Read	1	1	Read data									Read data from CG RAM or DD RAM.	40μs
	I/D = 1 : Increment S = 1 : Display Shift On D = 1 : Display On C = 1 : Cursor Display On B = 1 : Cursor Blink On S/C = 1 : Shift Display R/L = 1 : Shift Right DL = 1 : 8-Bit N = 1 : Dual Line F = 1 : 5x10 dots BF = 1 : Internal Operation BF = 0 : Ready for Instruction										I/D = 0 : Decrement S/C = 0 : Move Cursor R/L = 0 : Shift Left DL = 0 : 4-Bit N = 0 : Signal Line F = 0 : 5 X 8 dots	DD RAM : Display Data RAM CG RAM : Character Generator RAM ACG : Character Generator RAM Address ADD : Display Data RAM Address AC : Address Counter	

Note 1: Symbol "*" signifies an insignificant bit (disregard).

Note 2: Correct input value for "N" is predetermined for each model.

Note 3: The variation of execution time depends on the change of oscillator frequency; for example:

$$\text{if } f_{OSC} = 380\text{KHz, then execution time} = 40\mu\text{s} \times (540\text{KHz} / 380\text{KHz}) = 57\mu\text{s}$$

10. Font Characteristic

		Higher 4-bit (D4 to D7) of Character Code (Hexadecimal)																			
		0	1	2	3	4	5	6	7	8	9	A	B	C	D	E	F				
Lower 4-bit (D0 to D3) of Character Code (Hexadecimal)	0	CG RAM (1)			0	1	2	3	4	5	6	7	8	9	A	B	C	D	E	F	
	1	CG RAM (2)			!	1	A	Q	a	A						■	7	*	4	ä	g
	2	CG RAM (3)			"	2	B	R	b	r						┌	┐	└	┘	ρ	θ
	3	CG RAM (4)			#	3	C	S	c	s						┌	┐	└	┘	ε	ω
	4	CG RAM (5)			\$	4	D	T	d	t						┌	┐	└	┘	μ	α
	5	CG RAM (6)			%	5	E	U	e	u						■	*	*	1	o	ü
	6	CG RAM (7)			&	6	F	V	f	v						㊦	㊧	㊨	㊩	ρ	Σ
	7	CG RAM (8)			'	7	G	W	g	w						7	+	7	7	g	π
	8	CG RAM (1)			(8	H	X	h	x						4	0	*	U	7	㊦
	9	CG RAM (2))	9	I	Y	i	y						㊦	7	U	7	7	㊦
	A	CG RAM (3)			*	A	J	Z	j	z						㊦	㊦	㊦	㊦	㊦	㊦
	B	CG RAM (4)			+	B	K	0	k	<						㊦	㊦	㊦	㊦	㊦	㊦
	C	CG RAM (5)			,	C	L	1	l							㊦	㊦	㊦	㊦	㊦	㊦
	D	CG RAM (6)			-	D	M	2	m	>						㊦	㊦	㊦	㊦	㊦	㊦
	E	CG RAM (7)			.	E	N	3	n	+						㊦	㊦	㊦	㊦	㊦	㊦
	F	CG RAM (8)			/	F	O	4	o	+						㊦	㊦	㊦	㊦	㊦	㊦

11. BACKLIGHT CHARACTERISTICS

LCD Module with Edge LED Backlight

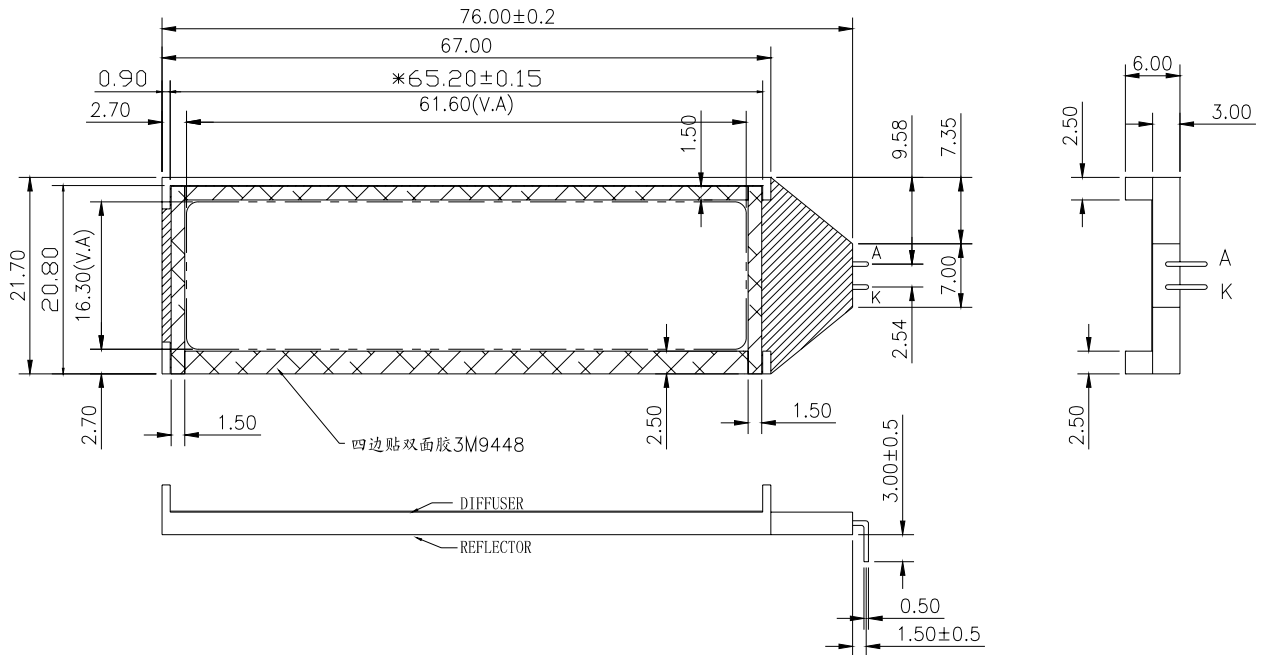

ELECTRICAL RATINGS

Ta = 25°C

Item	Symbol	Condition	Min	Typ	Max	Unit
Forward Voltage	VF	IF=15mA	2.9	3.1	3.3	V
Reverse Current	Ir	VR=5.0V	---	10	---	uA
Luminous Intensity (Without LCD)	Lv	IF=15mA	140	190	---	Cd/m ²
Wave length	λp	IF=15mA	X=0.26 Y=0.26	---	X=0.30 Y=0.30	
Color	White					

Note:

when the temperature exceed 25°C, the approved current decrease rate for Backlight change as the temperature increase is: -0.36mA/°C (below 25°C, the current refer to constant, which would not change with temperature).

12. ELECTRO-OPTICAL CHARACTERISTICS

($V_{DD}=5.0V$, $T_a = 25^{\circ}C$)

Item	Symbol	Condition	Min	Typ	Max	Unit
Operating Voltage of LCD	Vlcd	Ta = -20°C	4.7	5.0	5.3	V
		Ta = 25°C	4.2	4.5	4.8	
		Ta = 70°C	3.7	4.0	4.3	
Response time	Tr	Ta = 25°C	---	100	160	ms
	Tf		---	150	200	ms
Contrast	Cr	Ta = 25°C	---	4	---	---
Viewing angle range	θ	Cr \geq 2	-20	---	+20	deg
	ϕ		-30	---	+30	deg

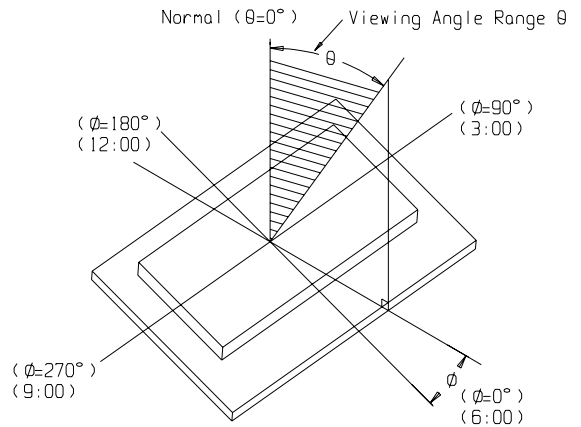
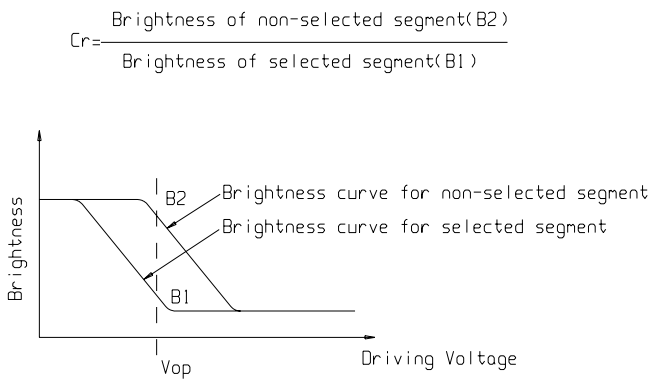

13. PRECAUTION FOR USING LCD/LCM

After reliability test, recovery time should be 24 hours minimum. Moreover, functions, performance and appearance shall be free from remarkable deterioration within 50,000 hours (average) under ordinary operating and storage conditions room temperature ($20\pm 8^{\circ}\text{C}$), normal humidity (below 65% RH), and in the area not exposed to direct sun light. Using LCM beyond these conditions will shorten the life time.

Precaution for using LCD/LCM

LCD/LCM is assembled and adjusted with a high degree of precision. Do not attempt to make any alteration or modification. The followings should be noted.

General Precautions:

1. LCD panel is made of glass. Avoid excessive mechanical shock or applying strong pressure onto the surface of display area.
2. The polarizer used on the display surface is easily scratched and damaged. Extreme care should be taken when handling. To clean dust or dirt off the display surface, wipe gently with cotton, or other soft material soaked with isopropyl alcohol, ethyl alcohol or trichlorotrifluoroethane, do not use water, ketone or aromatics and never scrub hard.
3. Do not tamper in any way with the tabs on the metal frame.
4. Do not make any modification on the PCB without consulting DISPLAY.
5. When mounting a LCM, make sure that the PCB is not under any stress such as bending or twisting. Elastomer contacts are very delicate and missing pixels could result from slight dislocation of any of the elements.
6. Avoid pressing on the metal bezel, otherwise the elastomer connector could be deformed and lose contact, resulting in missing pixels and also cause rainbow on the display.
7. Be careful not to touch or swallow liquid crystal that might leak from a damaged cell. Any liquid crystal adheres to skin or clothes, wash it off immediately with soap and water.

Static Electricity Precautions:

1. CMOS-LSI is used for the module circuit; therefore operators should be grounded whenever he/she comes into contact with the module.
2. Do not touch any of the conductive parts such as the LSI pads; the copper leads on the PCB and the interface terminals with any parts of the human body.
3. Do not touch the connection terminals of the display with bare hand; it will cause disconnection or defective insulation of terminals.
4. The modules should be kept in anti-static bags or other containers resistant to static for storage.
5. Only properly grounded soldering irons should be used.
6. If an electric screwdriver is used, it should be grounded and shielded to prevent sparks.
7. The normal static prevention measures should be observed for work clothes and working benches.
8. Since dry air is inductive to static, a relative humidity of 50-60% is recommended.

Soldering Precautions:

1. Soldering should be performed only on the I/O terminals.
2. Use soldering irons with proper grounding and no leakage.
3. Soldering temperature: $350^{\circ}\text{C} \pm 10^{\circ}\text{C}$
4. Soldering time: 3 to 4 second.
5. Use eutectic solder with resin flux filling.
6. If flux is used, the LCD surface should be protected to avoid spattering flux.
7. Flux residue should be removed.

Operation Precautions:

1. The viewing angle can be adjusted by varying the LCD driving voltage V_o .
2. Since applied DC voltage causes electro-chemical reactions, which deteriorate the display, the applied pulse waveform should be a symmetric waveform such that no DC component remains. Be sure to use the specified operating voltage.
3. Driving voltage should be kept within specified range; excess voltage will shorten display life.
4. Response time increases with decrease in temperature.
5. Display color may be affected at temperatures above its operational range.
6. Keep the temperature within the specified range usage and storage. Excessive temperature and humidity could cause polarization degradation, polarizer peel-off or generate bubbles.
7. For long-term storage over 40°C is required, the relative humidity should be kept below 60%, and avoid direct sunlight.

Limited Warranty

DISPLAY LCDs and modules are not consumer products, but may be incorporated by DISPLAY's customers into consumer products or components thereof, DISPLAY does not warrant that its LCDs and components are fit for any such particular purpose.

1. The liability of DISPLAY is limited to repair or replacement on the terms set forth below. DISPLAY will not be responsible for any subsequent or consequential events or injury or damage to any personnel or user including third party personnel and/or user. Unless otherwise agreed in writing between DISPLAY and the customer, DISPLAY will only replace or repair any of its LCD which is found defective electrically or visually when inspected in accordance with DISPLAY general LCD inspection standard . (Copies available on request)
2. No warranty can be granted if any of the precautions state in handling liquid crystal display above has been disregarded. Broken glass, scratches on polarizer mechanical damages as well as defects that are caused accelerated environment tests are excluded from warranty.
3. In returning the LCD/LCM, they must be properly packaged; there should be detailed description of the failures or defect.